

ANALYSIS OF INFORMATION SYSTEM SUCCESS IN THE COLLEGES IN EAST JAVA WITH WIJAYANTO'S APPROACH OF INFORMATION SYSTEM SUCCESS MODEL

Heri Wijayanto

*Faculty of Economics, Muhamamdiyah University of Ponorogo, Jalan Budi Utomo,
Ponorogo, 63471, Indonesia
lok_coi@yahoo.com*
*Corresponding Author

ARTICLE INFO

Article history

Received: 27/01/2020
Revised: 11/02/2020
Accepted: 21/02/2020

Keywords

Information systems
college
Top management support
Organization culture

ABSTRACT (10PT)

The era of globalization, “which is marked by reforms in the field of information, requires good top management support and can support the application of information systems for the creation of quality, useful, and competitive information. Information systems in colleges are tools for managers to complete both new roles and traditional roles, enabling managers to monitor, plan, and predict more precisely and quickly to respond quickly to changes in the business environment. The purpose of this study is to analyze the role of top management support as a moderating variable effect of product quality on use and analyze the role of organizational culture as a moderating variable the effect of the use on benefits. The population of this study was colleges in East Java, a sample of 164 colleges consisting of 57 colleges ranked in Webometrics, and 107 colleges ranked in Webometrics. The analysis came with the SEM-Amos 22 program. The results showed that top management support moderated the effect of product quality on pure use of moderation, and organization culture moderated the effect of the use on benefits in a quasi-moderation manner”.

This is an open access article under the [CC-BY-SA](#) license.



1. Introduction (bold, 12 pt)

Information technology as a pillar of national development, as Indonesia's information technology vision stated in the phrase "The realization of Indonesia as a strong country in global competition, through the development and utilization of information and communication technology for the formation of a knowledge-based prosperous society that adheres to the noble values of the nation" clearly visible strategies and expectations of the application of information technology in all fields in accordance with the context in order to create a national competitiveness" (Djokopranoto & Indrajid, 2010).

The development of information and communication technology has a huge impact on human civilization. The education sector is one of the communities that have direct or indirect responsibility for the process of planning, development, application, and development of information technology in accordance with its tasks and functions (Indrajid, 2011).

The higher education is "a level of education after secondary education that includes diploma programs, undergraduate programs, master's programs, doctoral programs, and professional programs, as well as specialist programs, which are organized by universities based on Indonesian culture (Indonesian Law no. 12 of 2012). Higher education is the second most complex type of organization in the world, after a hospital organization, this is due to the many types of stakeholders with different objectives" (Indrajid, 2011).

"The college as a provider of education, namely conscious and planned efforts to create an atmosphere of learning and learning process so that students actively develop their potential to have spiritual strength, self-control, personality, intelligence, noble character, and the skills needed by themselves, the community, nation and state" (RI Law no. 12 of 2012).

The task of college institutions is to promote the use of information technology by increasing information literacy in the community. Information literacy in a good category if the person concerned can investigate what information is needed in the context of certain conditions, can state it in appropriate terms, can search effectively for quality information from various available data sources, can conduct analysis based on results the collection of information, can use it for various positive purposes and bring significant value and can process it further into a resource of knowledge (Djokopranoto & Indrajid, 2010).

The National College Accreditation Agency (*BAN-PT*) "requires the application of information technology in tertiary institutions in terms of managing facilities and infrastructure that ensures broad access, especially for students and lecturers, through the use of shared resources (resource sharing). A good university information system is reflected in the ownership of a clear blueprint in terms of development, management and utilization of a complete information system, as well as ownership of a complete, effective, and objective decision support system" (*BAN-PT, 2011*).

"The college information systems include Academic information system (Siakad), Lecturer Career Development Information System (SIPKD), Higher Education Database (PDDikti), Simlitabmas, Sprott, self-evaluation, e-journal portal, e-journal, and e-learning. PPDikti is a process of recording and collecting data regulated in Law Number 12 of 2012 concerning Higher Education, and Minister of Research, Technology and Higher Education Regulation number 61 of 2016 which specifically regulates PDDikti feeder which has the ability to record and publish data in one database".

The benefits of applying information systems are "felt by many universities, but several problems arise including implementation of information systems is relatively difficult because of the integrated application, and organizations must change the way they do business. These problems if not anticipated quickly and precisely will result in failure marked by large investments, but the company does not obtain benefits and benefits optimally" (Brynjolfsson, 2006) or called the information technology paradox (IT Paradox).

The application of tertiary information systems is influenced by political and social dynamics in the campus environment. Issues of political and social dynamics include 1) Reluctance to change old behaviors and habits that work manually to later use information technology, 2) The use of information systems will make higher education management more transparent, efficient, effective, and well-controlled, things this can lead to serious social problems, 3) New standards due to the use of

ERP, requires the academic community to change the model of academic activities by implementing ERP, this will require special competence and expertise (Indrajid, 2011)

The decision to implement information systems is not an easy decision because the application of information systems requires high costs. Cost requirements are not only needed for purchasing information systems applications, but also for the purchase of hardware, databases, data communication networks and also the costs of consultants who assist the work of implementing the system. Management needs to know the level of successful implementation so IT paradoxes don't occur. Measuring the success of the application of information systems is very necessary for management to find out whether the investments that have been issued provide added value to the company (Tarigan, 2009).

Analysis of the success of information systems can be done using several models including DeLone and McLean (2003), Ifinedo (2007), Chien and Tsaur (2007), Wei and Loong (2009), and Hamed et al. (2012). DeLone and McLean (2003), and Wijayanto (2018). The model consists of six variables: system quality, information quality, service quality (product quality level), use, user satisfaction (user behavior level), and net benefit (profit level of system performance).

“The failure of the implementation of Information Technology in college business processes is not due to technical factors but rather to non-technical problems, namely: human factors, processes, and work organizations. The characteristics of tertiary institutions as an organization are classified in the form of loose organization, where the relations between sections are quite tenuous. The academic community must be seen as human and not a production machine, where informal relationships between members of the organization become very important” (Curry, 2002).

Colleges that succeed in improving their performance through the use of information systems depend on the readiness of campus human resources in changing their paradigms, mindsets, and daily behavior. Higher education institutions that implement information systems without being accompanied by changes in mindset and behavior will only lead to the implementation of an ancient campus that is increasingly expensive (Indrajid, 2011).

The role of top management support has proven to be significant in the successful implementation of information systems, so it is possible that top management support has an indirect role in influencing the level of product quality at the level of user behavior. Good product quality, without the support of good user behavior, implementation failure will occur. The role of management through their support and involvement is predicted to be able to improve from the level of product quality to the level of user behavior, as a technology transfer process to determine success.

2. Literature Review (bold, 12 pt)

Wijayanto's Information Systems Success Model (2018) states that the success of an information system is determined by several variables, namely: 1) Product quality as measured by system quality, information quality and service quality, 2) Use, 3) Benefits, 4) top management support, and 5) organization culture. With the interaction between variables as follows: Product quality affects the information system use, use affects the benefits, the effect of product quality on the information system used in moderation top management support, and the effect of the use of the information system on benefits in the moderation of the organizational culture. The complete model as in Figure 1.

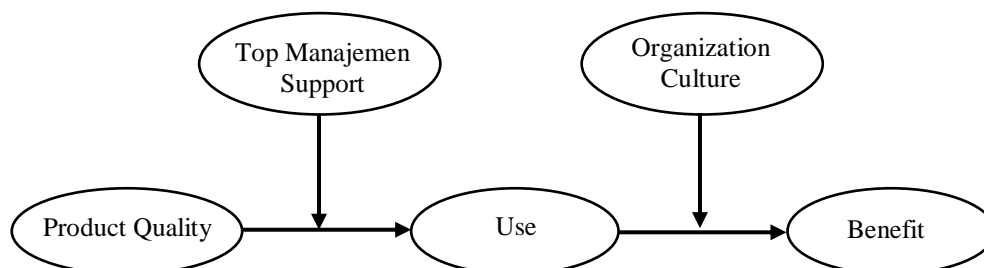

Figure 2. Wijayanto's Information System Success Model (2018)

Hypothesis

1. Top Management support moderates the effect of product quality on use
2. Organization culture moderates the effect of the use on benefits

Top Management Support

“Top management support is an activity that impacts, directs and maintains human behavior shown by directors, division heads, direct superiors, etc. Top management steps that can be used in providing support include: 1) Get to know the members of the organization and identify their needs, 2) set appropriate goals, 3) develop a reliable performance measurement system and provide feedback, 4) place workers according to ability and possessed talent, 5) provide support in completing tasks, 6) apply reward and punishment, and 7) act fairly, objectively and be an example” (Trisda & Dwirandra, 2013).

“Top management is committed to the time, cost, and resources to support suppliers to create long-term partnerships, and the company runs stably. Top management in running a business must always develop and create value for the company in order to improve organizational performance” (Chen & Paulraj, 2004).

“Commitment and leadership in top management in an organization is measured by effective leadership (Holland & Kumar, 1995), Visible (Carr & Smeltzer, 1997), and creative in thinking and understanding cooperation between companies (Krause, 1999). Top management support in information systems is seen from the extent to which management understands the importance of system functions, and their involvement in information system activities (Ragu-Nathan et al., 2004). This form of top management support is characterized by an interest in information systems and encourages collaboration between units” (Boynton et al., 1992).

Management of human resources information systems can only be done if the organization has human resources. The processes related to the recruitment, placement, training, supervision, evaluation, promotion and termination of the organization's human resources really need to be controlled seriously to ensure the sustainability and sustainability of the information system (Indrajid, 2011). Reliable process control related to human resources management, it is hoped that the organization will be able to prepare personnel who have the right motivation and competence to implement all system development initiatives. There are three constituent domains in tertiary institutions that need to be sharpened with competence and expertise related to the application of information systems, namely: 1) leaders, top management or key users, because they are the role models, 2) users who will use the information system as supporting activities of daily activities, and 3) Information systems division, as a party that will act as a bridge or guarantor for the technical and administrative support needed by all parties (Indrajid, 2011).

Culture in Utilizing ERP

Cultural aspects in the utilization of information systems can be grouped in 4 (four) domains, namely:

- a. Culture as part of the information system implementation process, as well as the user's view of the benefits provided by the information system, and self-perception of the technical ability to use information systems (Brown & Vankatesh, 2005).
- b. Culture as an impact of the implementation of information systems, namely how users adapt to the information system on the face after implementation. The cultural component of information system implementation includes the emotional stability of users, effective and efficient behavior at work, and initiatives to participate in minimizing negative impacts (Beaudry & Pinsonneault, 2005).
- c. Cultural aspects as an accelerator, namely culture can optimize the use of information systems in innovating that is influenced by interpersonal consisting of personal interests, abilities, a sense of empathy, and an attitude of trust in technology (Ahuja & Thatcher, 2003).
- d. Culture as a barrier to the acceleration of information systems (Lapointe & Ricard, 2005).

Unpreparedness in dealing with culture in the implementation of information systems as a system that supports the operational management of tertiary institutions will provide the possibility and flexibility for management to evaluate performance in all relevant lines or work units. Performance

evaluation that can be done with information systems includes: 1) the level of attendance of lecturers and timeliness in delivering lectures, 2) the index of student satisfaction with lecturer performance, 3) list of courses with an improper distribution of grades, 4) average graduation students who are on time, 5) the level of efficiency and utilization of the use of space, 5) the progress in increasing the value of permanent lecturers, 6) the number of complaints and student complaints per month, and 7) the timeliness profile submits the final grade course (Indrajid, 2011).

Information Systems in the College

“BAN-PT (2011) requires that college information system standards must have an information system prepared to support the management and improvement of the quality of academic programs. The information system in a tertiary institution consists of a minimum of data collection, data analysis, storage, retrieval, presentation of data and information, as well as communication with interested parties”.

“The development of information technology is very fast, so colleges must be able to carry out professional management and updates of hardware and software, human resources and management organizations to ensure the growth of the information system that has been built. Universities must also guarantee access for students, staff and other academicians to take advantage of the existence of the information system through transparent regulations” (BAN-PT, 2011). Higher education information system standards are assessed from several assessment elements determined by BAN-PT, which include:

- a. “The college has a clear blueprint about the development, management, and utilization of information systems including systems that regulate data flow, authorize data access and disaster recovery systems”.
- b. “The college has a decision support system (decision support system) to help leaders in planning and analyzing self-evaluation properly and more objective decision making”.
- c. “The information system owned is in the form of a database and information that minimally covers college finance, assets, facilities, and infrastructure, academic administration, profiles of students and graduates, lecturers and support staff”.
- d. “The college has an information system that is utilized for internal and external communication of the campus as well as access for students and lecturers on scientific information sources”.
- e. “The college has internet capacity with an adequate bandwidth ratio per student”.

Information System Implementation in the college

The PDDikti Feeder application has a positive impact on data management reported by each college. Growth of the colleges from year to year, student and lecturer ratios, classification of state and private colleges, college status, and number of professors can be monitored by stakeholder PDDikti is also integrated into professional certification instruments, such as the competency test of Indonesian doctors, the competency test of Indonesian accountants, and teacher competency tests.

A collection of data that has been mapped Pusdatin Kemenristekdikti can be one source of information. Data that has been analyzed can be a reference for students, prospective students, lecturers, colleges, even the public, and other institutions to see how the directory and the concrete condition of Indonesia's higher education today.

Information and communication technology and knowledge-based society cause paradigm changes in the implementation of higher education are not negotiable. “The main focus of Kemenristekdikti's performance remains on efforts to prepare generations who will compete in the national and international labor market, and will meet a variety of job opportunities. These reforms include the provision of flexible and student-oriented education and market share, curriculum changes, provision of lecturers, professors, and professional education staff” (Djokopranoto & Indrajid, 2010).

The benefits of information systems for colleges can basically be divided into 2 (two) broad categories. The first category is referred to as core values, which are related to the benefits obtained by tertiary institutions through the implementation of information systems related to the Tri Dharma of tertiary institutions. In this context, the main stakeholders include students (students), educators

(lecturers), researchers, and public servants. The second category is referred to as supporting values, which are related to the benefits derived by tertiary institutions through the implementation of information systems that are directly related to the management of higher education institutions.

The level of maturity of a college information system user, if categorized using the conceptual framework or Personal-Capability Maturity Model (P-CMM) theory, can be categorized into 6 (six) levels (Curtis et al., 2009), namely:

- a. "Level 0, if an individual does not know and does not care about the importance of information systems to support his work".
- b. "Level 1, if an individual has had one or two experiences where information is an important component for the achievement of desires and problem-solving".
- c. "Level 2, if an individual has repeatedly used information systems to help work activities and has a pattern of repetition in its use".
- d. "Level 3, if an individual already has a standard of mastery and understanding of the information and technology he needs, and consistently uses the standard as a reference for carrying out work activities".
- e. "Level 4, if an individual has been able to significantly improve (quantitatively stated) the performance of work activities through the use of ERP".
- f. "Level 5, if an individual has considered the information system an inseparable part of daily activities, and has directly or indirectly colored his behavior and culture".

3. Research Method (bold, 12 pt)

The population of this research is universities in East Java both State colleges (PTN) and Private colleges (PTS) which are within the scope of the Ministry of Technology Research and Higher Education (Kemenristekdikti) coordination and with an active status of 285 consists of 57 colleges ranked Webometrics, and 107 colleges not ranked Webometrics. An analysis tool using SEM on the Amos version 22 program.

Variable Operational Definitions, and Variable Measurement Techniques

The operational definitions of the variables are as follows:

- a. Product quality is "the quality of a combination of hardware and software in an information system. Focus on the performance of the system, including how well the ability of hardware and software can provide information on the needs of users in terms of ease of use, integration, understanding, and speed of response" (DeLone & McLean, 2003), concerning the accuracy of presentation, actual, time period, relevant, and complete (O'Brien, 2006), appearance, reliability, responsiveness, and guarantee (Parasuraman et al. 1988).
- b. Use refers to how often usage uses information systems, willingness to use, and motivation to use (DeLone & McLean, 2003).
- c. Benefits are benefits for individual users and the benefits for organizations include increased productivity, reduced operational costs, and organizational effectiveness (DeLone & McLean, 2003).
- d. Top Management Support is the participation and involvement of top management in the development of a system that is measured by the totality of support, involvement, informal relations, knowledge and innovation, and budget availability (Vanlommel & DeBrabander, 1975).
- e. Organizational culture is "the basic pattern accepted by organizations to act and solve problems, form employees who are able to adapt to the environment, and unite members of the organization, as measured by dominant characteristics, leadership type, management type, organizational glue, strategic emphasis, and criteria of success" (Cameron & Quinn, 1999).

Data analysis using Structural Equation Modeling (SEM) in the Amos 22 program. The analysis phase was carried out in two stages, namely estimating without entering interaction variables to get the loading factor and error variance value of the latent variables exogenous product quality, and estimating the model by entering variables interaction and loading factor values for interaction variables.

4. Results and Discussion (bold, 12 pt)

Hypothesis test results

Hypothesis 1: “top management support moderates the effect of product quality on use”.

“The first stage of data analysis is estimating without entering the interaction variable to get the loading factor and error variance value of the latent variable exogen product quality, as Figure 2”.

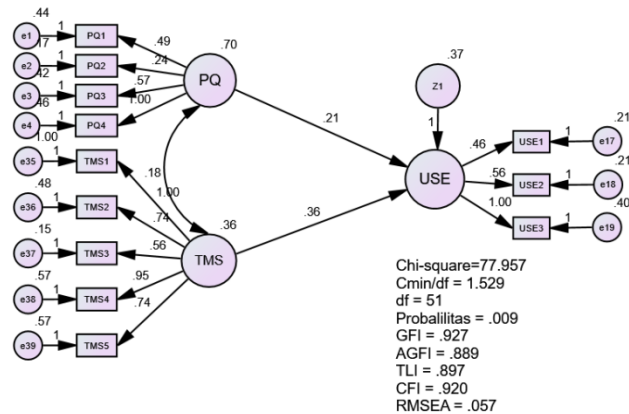

Figure 2 Stage I Product Quality and top management research model support to use without interaction variables

Table 1 Standardized Regression Weights Product Quality and Top Management support variables

Indicator Varibel	Estimate
TMS5	.254
TMS4	.359
TMS3	.428
TMS2	.286
TMS1	.263
PQ1	.279
PQ2	.189
PQ3	.352
PQ4	.605

Table 2 Square multiple correlation Product Quality and Top Management support variables

	Estimate
PQ4 <--- PQ	.778
PQ3 <--- PQ	.593
PQ2 <--- PQ	.435
PQ1 <--- PQ	.528
TMS3 <--- TMS	.654
TMS5 <--- TMS	.504
TMS4 <--- TMS	.599
TMS2 <--- TMS	.535
TMS1 <--- TMS	.513

Table 1 is used to calculate the loading factor of latent interaction variables, namely interactions between product quality and top management support, and Table 2 is used to calculate error variance values, with the formula:

$$\begin{aligned} \lambda \text{ interaksi} &= (\lambda_{pq1} + \lambda_{pq2} + \lambda_{pq3} + \lambda_{pq4}) \\ &\quad (\lambda_{tms1} + \lambda_{tms2} + \lambda_{tms3} + \lambda_{tms4} + \lambda_{tms5}) \\ &= (.528 + .435 + .593 + .778) \\ &\quad (.513 + .535 + .654 + .599 + .504) \\ &= 6,54687 \end{aligned}$$

$$\begin{aligned} \theta_q &= (\lambda_{pq1} + \lambda_{pq2} + \lambda_{pq3} + \lambda_{pq4})^2 (pq) \\ &\quad (\theta_{tms1} + \theta_{tms2} + \theta_{tms3} + \theta_{tms4} + \theta_{tms5}) + \\ &\quad (\lambda_{tms1} + \lambda_{tms2} + \lambda_{tms3} + \lambda_{tms4} + \lambda_{tms5})^2 (tms) \\ &\quad (\theta_{pq1} + \theta_{pq2} + \theta_{pq3} + \theta_{pq4}) + (\theta_{pq1} + \theta_{pq2} + \theta_{pq3} + \theta_{pq4}) \\ &\quad (\theta_{tms1} + \theta_{tms2} + \theta_{tms3} + \theta_{tms4} + \theta_{tms5}) \\ &= (.528+.435+.593+.778)^2 (.699) \\ &\quad (.263+.286+.428+.359+.254) + \\ &\quad (.513+.535+.654+ .599+.504)^2 (.357) (.279+.189+.352+.605) + \\ &\quad (.279+.189+.352+.605) (.263+.286+.428+.359+.254) \\ &= 18,9011 \end{aligned}$$

The results of the analysis of standardized regression weights as in Table 1 obtained the value λ of interaction = 6.54687, and the results of the analysis of square multiple correlations as in Table 2 obtained the value $\theta = 18.9011$.

The second stage of data analysis, estimating the model by entering the interaction variables and loading factor values for the interaction variables in the constraints with a value of 6.54687, and the error variance value of the interaction variables in the constraints with a value of 18.9011. The model after the interaction variable is entered as in Figure 3.

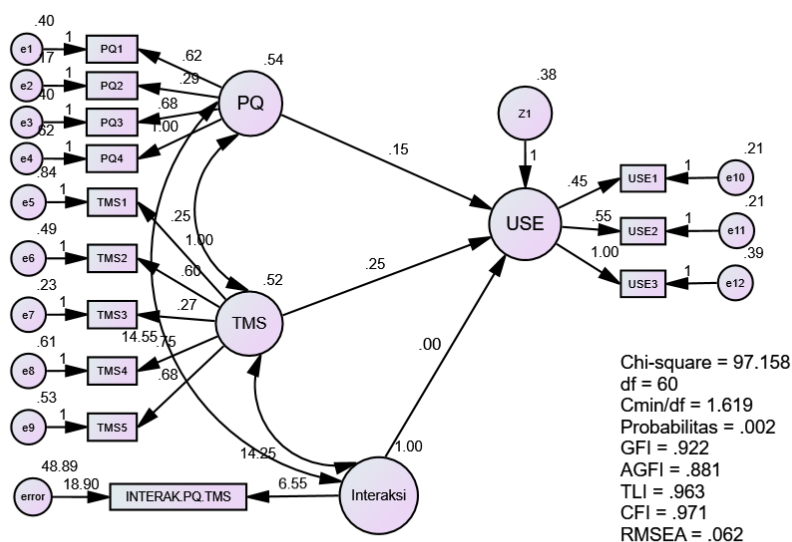

Figure 3 Model with interaction variables (product quality multiplied by top management support)

The significance of the parameter value of the effect of product quality on use, the effect of top management support on use, and the interaction variables between product quality and top management support are presented in Table 3.

Table 3 Regression Weight influence of product quality on use, the influence of top management support on use, and interaction variables (product quality multiplied by top management support)

		Estimate	S.E.	C.R.	P
USE	<--- Product quality	.149	.120	1.245	.213
USE	<--- Interaksi	.003	.001	3.926	***

The results of the inter-construct influence test as in Table 3 “show that product quality has no effect on use, indicated by the CR value obtained 1.245 and below the required value of > 1.96, and the probability value obtained 0.213, the value is above the predetermined significance level of 0, 05. The interaction variable between product quality and top management support influences the use with a probability value of 0,000, this shows that the top management support variable moderates the effect of product quality on us”.

The effect of product quality on use is not significant, and the effect of interaction variables on use is significant, so it can be concluded that the moderation type of top management support is pure moderation.

Hypothesis 2. “Organizational culture moderates the effect of the use of benefits”.

“The first stage of data analysis is estimating without including interaction variables to get the loading factor and error variance values of the latent variable exogen product quality”, as Figure 4.

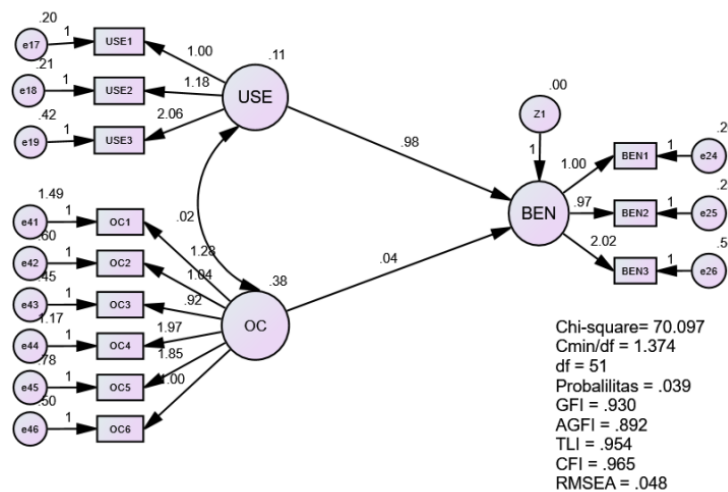

Figure 4 Phase I Research Model of use and organization culture to benefit without interaction variables

Table 4 standardized regression weights use variables and Organization culture

		Estimate
USE1	<--- USE	.590
USE2	<--- USE	.640
USE3	<--- USE	.721
OC6	<--- OC	.655
OC5	<--- OC	.789
OC4	<--- OC	.746
OC3	<--- OC	.646
OC2	<--- OC	.633
OC1	<--- OC	.542

Table 5 square multiple correlation variables use and Organization culture

	Estimate
OC1	.294
OC2	.401
OC3	.417
OC4	.557
OC5	.623
OC6	.428
USE3	.521
USE2	.409
USE1	.349

Table 4 is used to calculate the loading factor of latent interaction variables, namely the interaction between use and Organization culture, and Table 5 is used to calculate the error variance value, with the formula:

$$\begin{aligned} \lambda \text{ interaksi} &= (\lambda_{\text{use1}} + \lambda_{\text{use2}} + \lambda_{\text{use3}}) \\ &\quad (\lambda_{\text{oc1}} + \lambda_{\text{oc2}} + \lambda_{\text{oc3}} + \lambda_{\text{oc4}} + \lambda_{\text{oc5}} + \lambda_{\text{oc6}}) \\ &= (.590 + .640 + .721) (.542 + .633 + .646 + .746 + .789 + .655) \\ &= 7,825461 \end{aligned}$$

$$\begin{aligned} \theta_q &= (\lambda_{\text{use1}} + \lambda_{\text{use2}} + \lambda_{\text{use3}})^2 (\text{use}) \\ &\quad (\theta_{\text{oc1}} + \theta_{\text{oc2}} + \theta_{\text{oc3}} + \theta_{\text{oc4}} + \theta_{\text{oc5}} + \theta_{\text{oc6}}) + \\ &\quad (\lambda_{\text{oc1}} + \lambda_{\text{oc2}} + \lambda_{\text{oc3}} + \lambda_{\text{oc4}} + \lambda_{\text{oc5}})^2 (\text{oc}) \\ &\quad (\theta_{\text{use1}} + \theta_{\text{use2}} + \theta_{\text{use3}}) + (\theta_{\text{use}} + \theta_{\text{use2}} + \theta_{\text{use3}}) \\ &\quad (\theta_{\text{oc1}} + \theta_{\text{oc2}} + \theta_{\text{oc3}} + \theta_{\text{oc4}} + \theta_{\text{oc5}} + \theta_{\text{oc6}}) \\ &= (.590 + .640 + .721)^2 (.107) \\ &\quad (.294 + .401 + .417 + .557 + .623 + .428) + \\ &\quad (.542 + .633 + .646 + .746 + .789 + .655)^2 (.377) \\ &\quad (.349 + .409 + .521) + (.349 + .409 + .521) \\ &\quad (.294 + .401 + .417 + .557 + .623 + .428) \\ &= 12,34411 \end{aligned}$$

“The second stage of data analysis estimated the model by entering the interaction variable and the loading factor value for the interaction variable in the constraint with a value of 7.825461, and the error variance value of the interaction variable in the constraint with a value of 12.33411. The model after the interaction variable is entered as in Figure 5”.

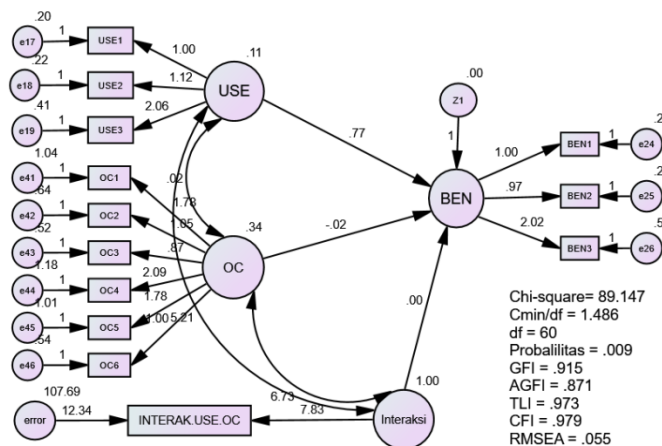

Figure 5. The model with Variable Moderation Interaction of multiplication of use and organization culture.

The significance of the parameter value of the effect of the use on benefits, the effect of organization culture on benefits, and the interaction variables between use and organization culture are presented in Table 6.

Table 6 Regression Weight influence of use on benefits, the influence of organizational culture on use, and interaction variables (use multiplied by organization culture)

			Estimate	S.E.	C.R.	P
benefit	<---	USE	.771	.124	6.231	***
benefit	<---	Interaksi	.004	.001	5.003	***

“The results of the inter-construct influence test show that use has an effect on benefits, marked by a CR value of 6,321, and above the required value of > 1.96, and a probability value of 0,000, the value is above the predetermined significance level of 0.05. Interaction variables affect the benefits with a probability value of 0,000, this shows that the organization culture variable is a moderating variable. The effect of the use on benefits is significant, and the effect of interaction variables on use is significant, so it can be concluded that the type of moderation of top management support is quasi moderation”.

Discussion

Top management support in implementing information systems has two main aspects, namely having a leadership spirit and providing the necessary resources. Top management must be able to show a leadership attitude. Top management support in colleges must have knowledge of appropriate information quality in the application of information systems to improve performance and help tertiary institutions to obtain maximum benefits.

The implementation of information systems in colleges influences organizations in line with agency theory which states that information technology makes it possible for organizations to reduce overall management costs and makes it possible to increase revenues, and management is able to reduce clerical work.

The implementation of information systems in colleges enables tertiary leaders to use technology to deal directly with lower-level operating units through telecommunications and computer networks, and eliminate intermediate-level intermediary managers. The use of information systems in tertiary institutions can alternatively distribute information to lower levels, which can then make decisions based on knowledge and information held without management intervention.

5. Conclusion

Product quality does not have a positive effect on use. The results of this study indicate that the better the quality system does not make the use of information systems in colleges in East Java is increasing. The effect of product quality on use is determined by the strengths and weaknesses of top management support as a pure moderation variable.

Use has a positive and significant effect on benefits. The results of this study indicate that the increasing use of information systems in colleges in East Java will increase benefits. The results of testing the influence of organizational culture dimensions in moderating the effect of the use on benefits in the implementation of college information systems in East Java shows that organizational culture is proven as a variable as a pure moderation variable.

Organizational culture, which is reflected in the emphasis on results, setting performance targets, maximizing work demands, having standard operational procedures, will strengthen the effect of the use on benefits. The college orientation that prioritizes service to students will be realized when *use* can be done well.

References

- Ahuja, M. K., J. B. Thatcher, 2005, "Moving Beyond Intentions and Toward the Theory of Trying: Effects of Work Environment and Gender on Post-Adoption Information Technology Use", *MIS Quarterly*, vol. 29, no 3, pp. 427-460.
- BAN-Perguruan Tinggi, 2011, *Kumpulan instrument standart 11 sistem informasi Perguruan Tinggi*, Departemen pendidikan Nasional.
- Beaudry, A., Pineseault A., 2005, "Understanding User Responses to Information Technology: A Coping Model of User Behavior", *MIS Quarterly*, vol. 29, no. 3, pp. 493-525.
- Boynton, Wiliam C., Johnson, Raymond N & Walter G. Kell., 2001, *Modern Auditing 7th Edition*, John Wiley & Sons, Inc, New York
- Brown, S., Venkatesh V, 2005, "Model of adoption technology in households: a baseline model test extension incorporating household life cycle", *MIS Quarterly*, vol. 27, no. 3, pp. 479-501.
- Brynjolfsson, 2006, "What Manager Should Know About ERP/ERP II", *Management Research New*, vol. 29, no. 4, pp. 184-193.
- Cameron and Quinn, 1999, *Diagnosing and changing organizational culture: Based on the competing value framework reading*, Massachusetts, addison-wesley publishing company, inc.
- Carr, A.S., Smeltzer, L.R., 1997, "An Empirically Based Operational Definition of Strategic Purchasing", *European Journal of Purchasing and Supply Management*, vol. 3, no. 4, pp. 199-207.
- Chen, I.J., Paulraj, A., 2004, "Towards of Theory of Supply Chain Management: the Construct and Measurement", *Journal of Operations Management*, vol. 22, pp. 119-150.
- Chien, S.W., Tsaor, S.M., 2007, "Investigating The Success of ERP System: Case Studies in Three Taiwanese High Tech Industries", *Computer in Industry*, vol. 58, no. 11, pp. 783-793.
- Curry J., R., 2002, *Web Portals and Higher Education*, Jossey-Bass, A Willey Company.
- Curtis B., Hefley B., Miller S., 2009, *People Capability Maturity Model (P-CMM) version 2.0, Second Edition*, Software Engineering Process Management. Carnegie Mellon University.
- DeLone, McLean, 2003, "The DeLone and McLean model of information system success: a ten-year updated", *Journal of management information system*, vol. 19, no. 4, pp. 9-30.
- Djokopranoto R., dan Indrajid R., E., 2010, *Manajemen Perguruan Tinggi Modern*, Sekolah Tinggi Manajemen Informatika dan Komputer Perbanas, dan Yayasan Atma Jaya, Jakarta.
- Hameed S., Javaid Butt, and Tariq, M., J., 2012, "The factors causing failure of foreign enterprises resource planning (ERP) systems in Pakistan", *African Journal of Business Management*, vol. 6, no. 3, pp. 946-955.
- Holland, D. and Kumar, S. (1995), "Getting past the obstacles to successful reengineering", *Business Horizons*, May/June, pp. 79-85
- Ifinedo, P., 2007, "Extending the Gable dkk. Enterprise Systems Success measurement model: a preliminary study", *Journal of Information Technology Management*, vol.17, no. 1, pp.14-33.
- Indrajid R., E., 2011, *Peranan Teknologi Informasi pada Perguruan Tinggi-Paradigma-Konsep-Strategi Implementasi*, APTIKOM.
- Krause, D.R., 1999, "The Antecedents of Buying Firm's Efforts to Improve Suppliers", *Journal of Operations Management*, vol. 17, no. 2, pp. 205– 224.
- Lapointe, L., S. Rivard, 2005, "A Multilevel Model of Resistance to Information Technology Implementation", *MIS Quarterly*, vol. 29, no 3, pp. 461-492.
- O'Brien, James A., 2006, *Introduction to Information System, 12th Edition*, McGraw Hill Companies Inc, New York.
- Parasuraman, 1998, "A multiple item Scale for measuring consumer perception of service quality", *Journal of retailing*, vol. 64, no. 1, pp. 12-40.

- Ragu Nathan, M. Tarafdar, Bhanu S., R-N, 2008, "The Consequences of Technostress for End Users in Organizations: Conceptual Development and Empirical Validation", *Information Systems Research*, vol. 19, no. 4, pp. 417-433
- Tarigan Zeplin, 2009, "Pengaruh implementasi ERP pada Product Differentiation dan cost Leadership dalam meningkatkan Kinerja Perusahaan", *Jurnal Manajemen pemasaran*, vol. 4, no. 1, pp. 11-15.
- Trisda Dewi S.A., dan Dwirandra A., 2013, "Pengaruh dukungan manajemen puncak, kualitas sistem, kualitas informasi, pengguna aktual dan kepuasan pengguna pada implementasi sistem informasi keuangan daerah di kota Denpasar", *e-jurnal akuntansi universitas Udayana*, vol. 4, no. 1, pp. 196-214.
- Undang-Undang Republik Indonesia nomor 12 tahun 2012, tentang Pendidikan Tinggi.
- Vanlommel, E., and DeBander, B., 1975, "The Organization of EDP Activities and Computer Use", *Journal of Bussiness*.
- Wei, K. S., Loong, A. C., Leong, Y. M., & Ooi, K. B., 2009, "Measuring ERP system success: a respecification of the Delone and McLean's IS success model", *Paper presented at the Symposium on Progress in Information and Communication Technology (SPICT'0)*, Kuala Lumpur, Malaysia.
- Wijayanto, 2018, Model kesuksesan system informasi, <http://oipas.sentraki.umpo.ac.id/model-kesuksesan-sistem-informasi-1>