

A Model to Get Positive Word of Mouth for Indonesian Footwear Brands: Role of Information Search, Online Engagement, Memorial Brand Experience and Brand Social Connection

by Umi Farida

Submission date: 13-Apr-2020 10:06AM (UTC+0700)

Submission ID: 1296119674

File name: ement,_Memorial_Brand_Experience_and_Brand_Social_Connection.pdf (550.57K)

Word count: 6412

Character count: 35495



1

International Journal of Innovation, Creativity and Change. www.ijicc.net
Volume 11, Issue 6, 2020

6

A Model to Get Positive Word of Mouth for Indonesian Footwear Brands: Role of Information Search, Online Engagement, Memorial Brand Experience and Brand Social Connection

Abdul Samad^a, Pande Ketut Ribek^b, Sudarmo^c, Yayuk Indah Wahyuning Tyas^d, Umi farida^e, ^aUniversitas Fajar, ^bFakultas Ekonomi dan Bisnis Universitas maharaswati Denpasar Bali, ^cSekolah Tinggi ilmu Ekonomi Balikpapan, ^dUniversitas Panca Marga, ^eUniversitas Muhammadiyah Ponorogo, Email: ^aabdulsamad@unifa.ac.id, ^bpandeketutribek@unmas.ac.id, ^csudarmo@stiesbalikpapan.ac.id, ^dyayuk@upm.ac.id, ^eumifarida899@gmail.com

This study investigated the drivers of positive word of mouth in the footwear industry of Indonesia with the inclusion of social identity and signalling theory. The study analysed the role of online engagement, memorial brand experiences and information search on word of mouth. Also the mediating role of brand social connection was examined in the relationship between word of mouth and its drivers. The primary data was drawn from a sample size of 302. Confirmatory Factor Analysis and Structural Equation Modelling approach was used in the study. Several test were applied including: descriptive analysis, KMO, Bartlett's Test, rotated component matrix and convergent and discriminant validity. The direct effects indicated that memorial brand experience and information search are significant and positive drivers of word of mouth. While online engagement was found to be an insignificant variable for driving word of mouth. On the other hand, the indirect effects showed that brand social connection acts as a significant mediator between online engagement and word of mouth. Also, brand social connection significantly mediated the relationship of memorial brand experience and word of mouth. Contrary, brand social connection does not act as a significant mediator between information search and word of mouth. The study embraces several



theoretical, practical and policy making implications for marketing management practitioners and strategy developers to boost word of mouth with customer satisfaction.

Key words: *Words of Mouth, Information Search, Online Engagement, Memorial Brand Experience, Brand Social Connection.*

Introduction

Word of mouth is emerging as a prominent concept with multiple drivers. It becomes extremely significant for organisations to establish and maintain relationships with their stakeholders; specifically with customers in order to gain positive word of mouth benefits (Babić Rosario, Sotgiu, De Valck, & Bijmolt, 2016). As the underlying purpose of every business and industry is maximisation of profits, attainment of customer loyalty and customer satisfaction. These expectations are met with the positive role of customers also as they become the co-creators and fosters word of mouth among others (You, Vadakkepatt, & Joshi, 2015). The advancement of new communication technologies alters the ways in which companies interact with their customers. Also the expectations of customers from brands have changed. It enables the firm to foster profitable exchanges and boost satisfaction of customers. This led towards the creation of positive word of mouth. The new interaction channels of communication that have emerged are e-mails, Web 2.0 tools and mobile phones to maintain and enhance relationships with customers. These will ultimately led towards effective communication and positive brand experiences and result in positive word of mouth (Hudson, Roth, Madden, & Hudson, 2015).

Almost every industry is facing the challenge of high competition and customer retention due to a dynamic business environment. This requires the implementation of strategies to expand the customer base and generate positive brand perceptions among customers in order to survive in the business industry. Word of mouth is a significant predictor of customer retention and attraction (Syahrivar & Ichlas, 2018). The most significant driver for the global footwear market is the rising importance of emerging markets not only as production businesses but also as customer demand driven markets. The global demand for footwear is increasing with a high growth rate as shown in Figure 1 (Cindy & Balqiah, 2018).



Figure 1: Global Footwear Demand



Source: Transparency Market Research on Footwear

Worldwide, the total production of Indonesia's footwear industry was 1.41 billion pairs of shoes; this amounts to 4.6% of the total world's production. It makes Indonesia the 4th largest producer of footwear in the world after China, India and Vietnam. Also, the revenue in the footwear market amounts to US\$4,006m in 2019. The market is expected to grow with a compound annual growth of 5.4% from 2019 to 2023. The statistics show that 30% of the total revenue in the footwear market will be generated through online sales by 2023 (Rachbini, Haryani Hatta, & Evi, 2019). The current sales are indicated in Figure 2.



Figure 2: Footwear E-commerce sales in Indonesia from 2014-2019 (in billions of Indonesian rupiah)

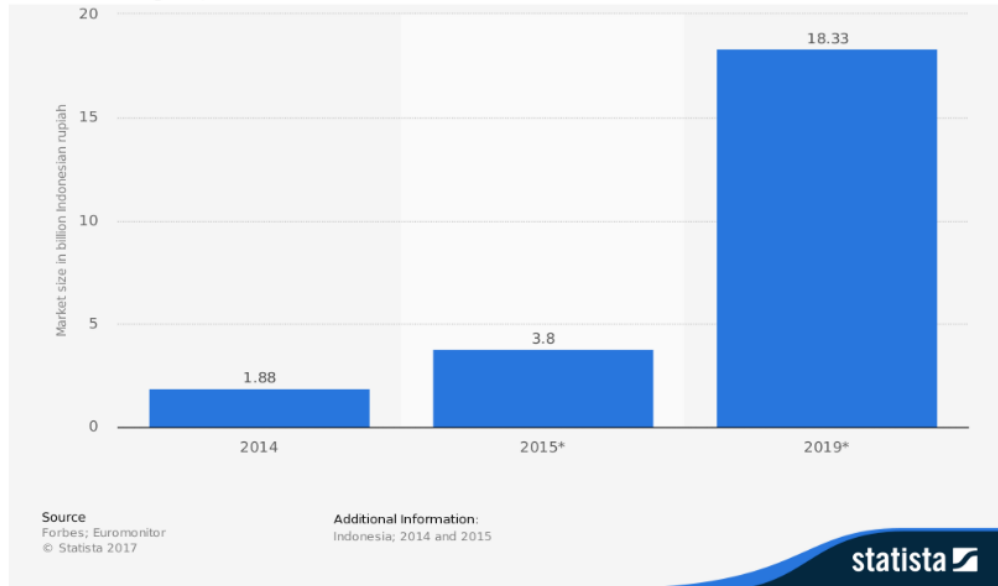

Thus, it is imperative for successful businesses to realise the importance of the role played by marketing tactics in the overall performance of a business and the creation of word of mouth. To overcome this challenge, several studies have been conducted around the globe to explore the influence of positive word of mouth; but mixed results were reported. According to some scholars, brand experience leads towards word of mouth. Whereas, other studies claimed that availability of easily accessible information leads towards recommendation and referrals (Sutia, Adha, & Fahlevi, 2019). Therefore in view of these findings, the researchers have focused on the impact of various word of mouth drivers (Mattsson & Söderlund, 2017; Setiawan, 2018; Wang & Yu, 2017). No such studies have been conducted to analyse the role of Online Engagement, Memorial Brand Experience and Information Search on positive word of mouth in the footwear sector of Indonesia; as it is the prominent growing sector. Also the mediating role of Brand Social Connection in the relationship between Online Engagement, Memorial Brand Experience, and Information Search on positive word of mouth has not been examined.

In view of the importance of word of mouth for the footwear industry and above-mentioned research gaps, it became essential to analyse the impact of various word of mouth drivers in relation to boosting customer demand in this industry. Thus, by following the suggestions of previous studies by (An, Do, Ngo, & Quan, 2019; Boateng, 2019; Yu, Liu, Lee, & Soutar, 2018) this research has the following objectives:



1. To determine the impact of information on positive word of mouth of footwear brands in Indonesia.
2. To analyse the impact of online engagement on positive word of mouth of footwear brands in Indonesia.
3. To investigate the impact of memorial brand experience on positive word of mouth of footwear brands in Indonesia.
4. To investigate the mediating role of brand social connection in the relationship between online engagement, information search, memorial brand experience and word of mouth of footwear brands of Indonesia.

Moreover, unlike previous studies, the current study incorporated advanced methodological techniques such as Structural Equation Modelling and Confirmatory Factor Analysis. The explanation of the proposed mechanism is significant for the marketing management practitioners to develop marketing strategies that encourage positive word of mouth and brand social connection. This paper includes: the relevant literature on marketing performance; hypotheses; the methodology of the study; data analysis and results and a conclusion and future policy implications.

Literature Review

Theoretical Background

In this study we used the Social Identity Theory (Hogg, 2016) and Signalling Theory (H⁶ Li, Fang, Wang, Lim, & Liang, 2015) in order to develop the framework to understand the role of information search, online engagement, memorial brand experience and brand social connection in generating positive word of mouth. Signalling Theory and Social Identity Theory are used to explain how the phenomenon pertains to antecedents of word of mouth and the role of brand social connection in its determination. Signalling Theory comprises three major elements: signaller, the provider of service or product; receiver, the customer; and the signal itself (Carragher, 2015). The firm influences the opinions of its customers by providing various signals through information, memorial brand experiences and online engagement; to foster positive word of mouth among customers. The firm wants to gain the trust of customers and foster word of mouth by providing information easily accessible through a variety of medium (J. Li, Tang, Jiang, Yen, & Liu, 2019). In the current era organisations rely on IT feature for sending signals to their customers and stakeholders with the intention of creating positive perceptions and behavioural intentions; leading to word of mouth. Therefore this study considers online engagement, memorial brand experience and information searching as the signals or the sources to boost positive word of mouth among customers (Su, Peng, Tan, & Cheung, 2016).



Whereas, social identity theory explains how brand social connection leads towards positive word of mouth. According to the theory individuals are motivated and inclined towards developing and maintaining their social identities and belonging to the groups and brands which reflects their personality (Garcia-Prieto & Scherer, 2016). When they feel connected with a brand and perceive it as a reflector of their social connection, they act as the brand ambassadors and recommended that same brand to others in order to build stronger connection (Meyer, Durrheim, & Foster, 2016). Several studies have incorporated the theories for an in-depth understanding of word of mouth mechanism. Thus, this study proposed the following conceptual model based on social identity and Signalling Theory, presented in Figure 3. It takes into consideration online engagement, memorial brand and experience and information search (independent variables) as the determining factor of word of mouth (dependent variable). The study also assumes that brand social connection acts as a significant mediator in the relationship between online engagement, memorial brand experience, information search and word of mouth.

Information Search and Word of Mouth

Information searching behaviours has been extensively researched by various scholars. The underlying motivations for searching the brand related information is the reduction of future risks associated with purchases (Chung & Koo, 2015). A critical evaluation of brand related information was done prior to the purchase decision. The researchers indicated that when the customer found negative information about the brand so, the research process further deepens and ultimately it results in the positive impact due to searching of complete information about the brand (Park, O'Hare, Schifanella, Jaimes, & Chung, 2015). It is evidenced that as time spent on searching about a particular product or service increases, so does the intentions of purchase. This in turn increases the chances of recommendations to others.

Also, it has been noted by (Chang & Huang, 2019) that the availability of information is the most prominent source in positive behavioural intentions and attachment of customers towards the brand. Moreover, it leads towards consistency in high customer value through high recommendation levels by customers to others (Lee, Cheng, & Shih, 2017). In addition, the information search helped customers to explore the current products and be able to make an informed decision. In order to achieve high levels of word of mouth and customer trust, the firms provided easy to use websites and all necessary information related to the brand (Zarrad & Debabi, 2015). The firms want to gain the trust of customers and fosters word of mouth through information converted into multiple signals through a variety of mediums (Herrero, San Martín, & Hernández, 2015). Therefore, in view of the literature review findings and with recognition of the important role of information search in the determination of positive word of mouth, this study hypothesized:



H1: Information search has a significant impact on word of mouth.

Memorial Brand Experience and Word of Mouth

Huge differences lie amongst customers with regards to their perception of brand experiences. It is shown from previous research that identification of a person with a brand depends upon his or her prior positive memorable brand experiences (Klein, Falk, Esch, & Gloukhovtsev, 2016). It is evidenced that these positive memorable experiences are the reasons for customer loyalty and repurchases. Also it leads towards positive word of mouth and strong connection about the particular brand. These experiences can predict the customer positive behaviour and perceptions of customers towards the product or service contributed towards positive word of mouth. Khan and Rahman (2015) investigated the factors that are responsible for positive word of mouth and found that prior experiences of customers with the company extensively determined a positive behaviour among customers. Also, it was revealed from the empirical results that the implementation of strategies focused on providing positive and memorable experiences to customers build positive emotions among them and proved to be the viral predictor of word of mouth (Riivits-Arkonsuo & Leppiman, 2015). Therefore based on the reviewed literature and recognizing the important role of prior brand experiences in the determination of positive word of mouth, this study hypothesised:

H2: Memorable brand experience has a significant impact on word of mouth.

Online Engagement and Word of Mouth

Engagement of customers is defined as “the intensity of an individual’s participation and connection with the organisation’s offerings and activities initiated by either the customer or the firm” (p. 1)(Zhang, Hu, Guo, & Liu, 2017). It is considered as a medium to gauge the preferences and needs of customers through their loyalty and attachment with the brand. It also determines the predictive purchase intentions of customers and their referrals (Chu, Lien, & Cao, 2019). Online engagement of customers emerged through social media and results in the creation of potential opportunities for providing improved services to the customer. The behaviour was reflected through the liking and commenting process on the shared content of the social media managed by the firm (Islam & Rahman, 2016). Similarly, it was evidenced from the findings (Rialti, Zollo, Caliendo, & Ciappei, 2017) that for the generation of word of mouth, the relationship marketing aspects are one of the crucial success factors for the company to enhance customer engagement. Also, it was postulated that developing relationships with customers through a social media presence and with online engagement fosters trust, sharing of information and positive behaviours. This led towards the customer becoming a co-creator of value and towards creation of positive word of mouth (Baker, Donthu, & Kumar, 2016)



In addition, online engagement plays a prominent role in fostering positive word of mouth for a product or service and aims to meet the needs of customers; as customers contributed as brand ambassadors (Mathwick & Mostell, 2017). Many studies have emphasised the importance of online engagement for the creation of word of mouth. While studying the major determinants of word of mouth the findings of (Zhao, Liu, Lai, Zhang, & Zhang, 2016) highlighted that the importance of implementation of online engagement resulted in positive customer experiences and their referrals. Therefore, based on the reviewed literature and the recognition of importance of online engagement in the determination of positive word of mouth, this study hypothesised:

H3: Online engagement has a significant impact on word of mouth.

Mediating Role of Brand Social Connection

Brand Social Connection is the “extent to which the customers feels associated and connected with the users of a particular brand” (Ahmad & Thyagaraj, 2015). It is indicated from previous studies that emotional connections are developed for the users of the brand and this creates a sense of social connection, as indicated by Social Identity Theory (Kucukemiroglu & Kara, 2015). Brand Social Connection leads towards positive word of mouth. According to this theory, individuals are motivated and inclined towards developing and maintaining their social identities and belonging to the groups and brands which reflect their personality. When they feel connected with a brand and perceive it as a reflector of their social connection, they act as the brand ambassador and recommend others to that brand in order to build a stronger connection (Wu, Fan, & Zhao, 2018). It is argued by the authors that Brand Social Connection is created with social groups and results in emotional connections. While searching information for a particular brand, the customer interacts with various social media platforms. Bloggers and others website reviewers builds the brands social connection with like-minded people. Also, online engagement activities of firms in the form of social media pages and reviews connects various proponents of the same brand provides ways for the customer centred marketing strategy according to their emotional connection and lead towards high levels of word of mouth (Zhang et al., 2017). Moreover, it was highlighted by Anam and Faiz (2016) that past memorable experiences play a significant role in the process of social connection building and positive word of mouth creation. Thus in view of the interrelated indirect relationship between online engagement, information search, memorial brand experience, brand social connection and word of mouth, this study hypothesised:

H4: Brand Social Connection has a significant mediating role in the relationship between information search and word of mouth.

H5: Brand Social Connection has a significant mediating role in the relationship between memorial brand experience and word of mouth.



H6: Brand Social Connection has a significant mediating role in the relationship between online engagement and word of mouth.

Figure 3: Conceptual Model

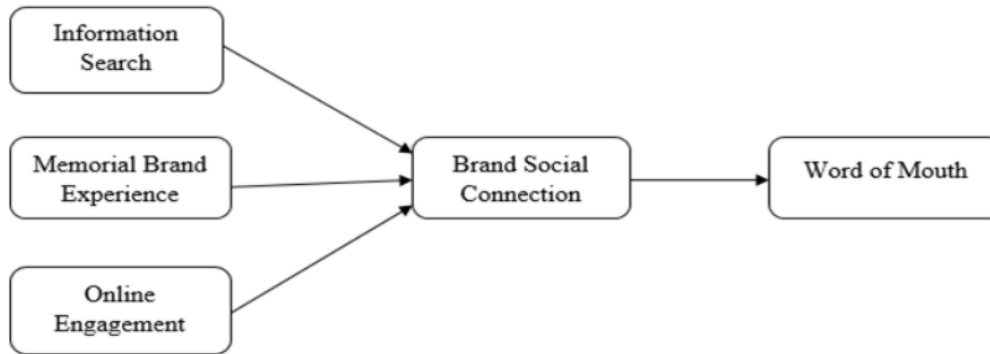

Research Methodology

Population and Sampling

This study examined the role of information searching, online engagement and memorial brand experiences in creating positive words of mouth, in mediating effect of brand social connection. The researcher target the Indonesia footwear brands for observing the impact of proposed study as Indonesia foot wear industry also contribute in global market share or in economy of Indonesia because Indonesia export the high-quality shoes and it became 52% of the export of the Indonesia. Indonesia is also positioned as the 4th ranked country in world footwear production. However to create market demand in the other countries or to increase the export revenue, some measures have to be taken to develop positive word of mouth. In this study it has been proposed that by providing superior values to customers in the form of relationship building and online services, the company can create positive word of mouth. The researcher collected the data for this study from employees and managers of the marketing department of Esmee Official, Winston Smith and Andre Valentino. The researcher used the purposive sampling technique for sample selection as the brands have many departments. As the main focus is the marketing department the researcher selected only marketing department employees. The survey questionnaires were distributed to 360 respondents and from that number 302 valid responses were collected. Those discarded were due to invalidity and incompleteness.



Data Collection Procedure

The most appropriate survey instrument for data collection, using a survey strategy, is a questionnaire. This was structured using two categories of closed ended questions such as variable scale items category and demographic questions category. The researchers wanted to collect objective responses not subjective detail about variables; therefore they chose closed ended questions. The language of the questionnaire must be native Indonesia language for the data collection process. After data collection the researcher can translate it into English language for easy data analysis. The researcher performed a pilot study on 25 respondents to find out whether the respondents could understand the items. . Afterwards the researcher used a self-administering technique, in which respondents are visited to solve any queries they had from the questionnaire..

Measures

Different authors have conducted research on the proposed variables through different perspective; therefore for this study the researcher adapted the measurement items from their research. For information search 3 measurement items have been adapted from (Crotts, 1999), (Mason & Scammon, 2011) & (Verplanken, 1993). For online exchange 4 measurement items have been adapted from earlier research work of (Cobos, Wang, & Okumus, 2009) & (Guo, 2014). Brand social connection, has been measured through 5 survey items adapted from (Lobschat, Zinnbauer, Pall, & Joachimsthaler, 2013) & (Fischer, Völckner, & Sattler, 2010) and for word of mouth 3 survey items have been taken from the work of (Alexandrov, Jilly, & Babakus, 2013). The researcher measured the responses of respondents through a 5-point Likert Scale, in which 1 stands for strongly disagree and 5 stands for strongly agree.

Data Analysis

The researcher analysed the data with the descriptive statistics test, reliability test, correlation test, regression test and with the help of SPSS software. Reliability of data has been assessed through two criteria such as (1) Cronbach's alpha and (2) Composite reliability. Both must have the values in a threshold range greater than 0.70 to confirm the items reliability and the internal consistency of the data. FAMOS has also been used for data analysis to run a diagnosis of confirmatory factor analysis. This has been used for assessing convergent validity, discriminant validity and model fitness. Moreover, AMOS has also been accompanied for running structure equation modelling, which runs for hypothesis testing or structural model analysis.



Data Analysis and Interpretation

In this study 302 questionnaires were distributed. The demographic details of respondents were: 124 males and 178 were females; the number of females had a higher education; 23 of the respondents were graduates, 147 postgraduates; 122 completed their Masters and 10 had some other degree. Age wise: 55 of the respondents were between 21 to 30 years old; 118 were from 31 to 40; 107 of the respondents were 41 to 50 years old; and 22 were 50+ in age.

Descriptive statistics

Table 1: Descriptive Statistics

	N	Minimum	Maximum	Mean	SD	Skewness	
	Statistic	Statistic	Statistic	Statistic	Statistic	Statistic	SD
BraSocCon	302	1.00	5.00	3.4894	1.07293	-.696	.140
WordofMou	302	1.00	5.00	3.4272	1.11916	-.510	.140
InfoSearch	302	1.00	5.00	3.5839	1.11607	-.829	.140
MemBasExp	302	1.00	5.00	3.5486	1.10422	-.805	.140
OnlineEng	302	1.00	5.00	3.5166	1.09824	-.726	.140
Valid (listwise)	N 302						

Table 1 shows the descriptive statistics of the study. Descriptive statistics provide detailed explanation about the variables in the study. They show that the descriptive coefficients give a complete summary of data. This set of data represents the entire sample of the population. The data shows that there is no outlier because the maximum values are in the threshold range of 5-point Likert Scale and the value of skewness is between -1 to 1. This is in the threshold range of normality therefore the data is normal and valid and suitable for further testing.



Table 2: Rotated Component Matrix

	Component				
	1	2	3	4	5
IS1				.765	
IS2				.859	
IS3				.813	
ME1					.793
ME2					.809
ME3					.836
OE1		.772			
OE2		.822			
OE3		.844			
OE4		.810			
BS1	.741				
BS2	.789				
BS3	.802				
BS4	.789				
BS5	.781				
WM1			.826		
WM2			.856		
WM3			.867		

Table 2 of rotated components matrix shows that almost all of the indicators have a factor loading of more than 0.7. This means that all indicators are eligible to be exposed to further hypothesis testing techniques because all the factors are in a suitable threshold level and valid sequence and range. Therefore this data is good for further testing techniques. There is no cross loading in the data shown in RCM so the data is reliable.

Table 3: Convergent and Discriminant Validity

	CR	AVE	MSV	MaxR(H)	BS	IS	ME	OE	WM
BS	0.893	0.627	0.319	0.895	0.792				
IS	0.882	0.714	0.335	0.942	0.562	0.845			
ME	0.898	0.746	0.335	0.964	0.565	0.579	0.864		
OE	0.896	0.682	0.309	0.973	0.502	0.556	0.519	0.826	
WM	0.884	0.717	0.277	0.978	0.476	0.346	0.526	0.447	0.847

The validity master sheet was used in order to confirm the convergent and discriminant validity for the research model variables. The discriminant validity provided the discrimination between variables while the convergent validity was measured with the help of

8

composite reliability and average variance extracted. The results of the validities are shown in the Table 3. The results and convergence of each variable is more than 70%. The average variances extracted is more than 50%, while the discriminate validity showed that the loading of each variable discriminates from each other. Every variable has maximum loading with itself as compared with others. Therefore these validities prove the authenticity of the collected data.

Confirmatory Factor Analysis

Table 4: Confirmatory Factors Analysis

Indicators	Threshold range	Current values
CMIN/DF	Less or equal 3	2.134
GFI	Equal or greater .80	.915
CFI	Equal or greater .90	.961
IFI	Equal or greater .90	.961
RMSEA	Less or equal .08	.061

10

Table 4 is of CFA. This is the confirmatory factor analysis used to confirm the fitness of hypothetical model before structural equation modelling. The results show: CMIN is less than 3; GFI is more than 0.80; CFI is more than 0.90; IFI is more than 0.90; and RMSEA is less than 0.08. All of the results show that the data is in a valid range and is good for further testing. Following is the screen shot of CFA in Figure 4.

Figure 4: CFA

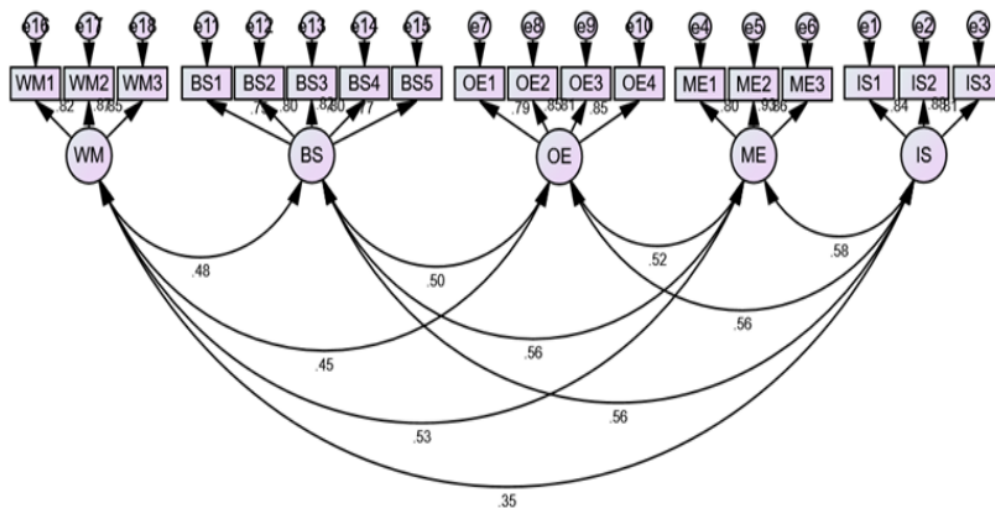
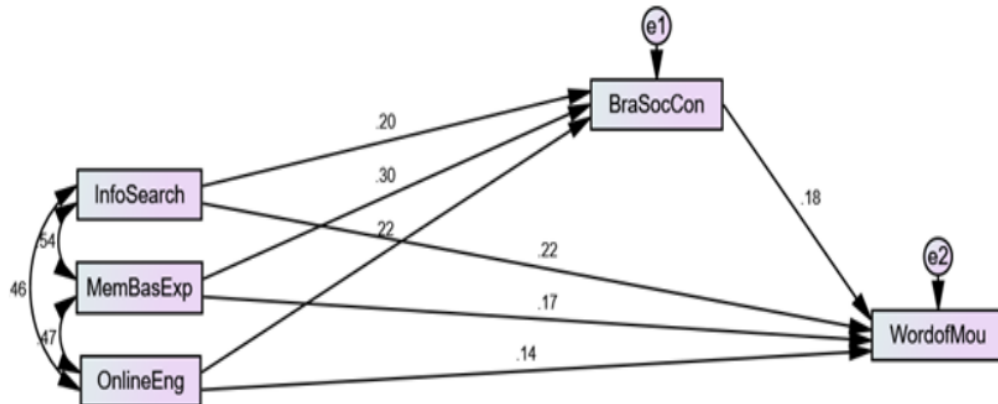

Table 5: Structural Equation Modeling

Total Effect	OnlineEng	MemBasExp	InfoSearch	BraSocCon
BraSocCon	.217**	.297***	.195*	.000
WordofMou	.181**	.226**	.255**	.177*
Direct Effect	OnlineEng	MemBasExp	InfoSearch	BraSocCon
BraSocCon	.217**	.297**	.195*	.000
WordofMou	.142	.174*	.220**	.177*
Indirect Effect	OnlineEng	MemBasExp	InfoSearch	BraSocCon
BraSocCon	.000	.000	.000	.000
WordofMou	.038*	.053**	.035	.000

Table 5 of SEM shows the relationships of different variables with each other and what impact they have on each other. The impact of OE on WOM is insignificant. The impact of MBE on WOM is 17% and is significant. The impact of IS on WOM is 22% and is significant and the impact of BSC on WOM is 17% and is significant. The overall model is significant.

Figure 5: SEM



Discussion and Conclusion

Discussion

This study aim to analyse the footwear brands of Indonesia to find out how what impacts Information Search (IS), Memorial Brand Experience (MBE) and Online Engagement (OE) had on Word of Mouth (WOM). The study took Brand Brand Social Connection (BSC) as a mediator. The first hypothesis proposed by the study was that “OE has a significant impact on WOM”. This hypothesis is rejected according to the analysis and past literature of (Hasegawa



& Matsuoka, 2015). The second hypothesis was that “MBE has a significant impact on WOM” this hypothesis is accepted, as brand experiences enhanced the WOM of the brand by the consumers to other potential customers (Kirono et al., 2016). The third hypothesis proposed by the study was that “IS has a significant impact on WOM”. This hypothesis is accepted as well because the ease of information search provides a base to the consumers for creating positive WOM about the brands and also attracts potential customers through the already existing consumers (Kis-Katos & Sparrow, 2015). The fourth hypothesis proposed was that “BSC has a significantly mediating role between SI and WOM”. This hypothesis is accepted. BSC promotes permanent connection between the brands and its consumers which help in creating a positive WOM about the brands and this mediator is also seen to be also significantly enhancing the IS (Mukhlis, Utomo, & Soesetio, 2015). The fifth hypothesis proposed by this study was “BSC has a significant mediating role between MBE and WOM”. This hypothesis is accepted as well. According to the results of the analysis MBE has an enhanced impact through BSC on WOM. The sixth hypothesis proposed by the study was that “OE and WOM are significantly mediated by the BSC”. This hypothesis is accepted as it is seen that the impact of OE is enhanced with the presence of BSC (Sidharta & Affandi, 2016).

Conclusion

This study aimed to analyse the footwear brands of Indonesia, to find out the impact of IS, MBE and OE on WOM. The study took BSC as a mediator. The data was collected by distributing questionnaires to 302 participants from the footwear brands of Indonesia. The results showed that OE does not significantly impact WOM whereas IS and MBE have a significant and positive impact on WOM. Moreover, BSC significantly mediates between all variables.

Implications of the Study

The study has focused on the footwear brands of Indonesia and the results are applicable for any footwear brands worldwide. WOM is important for any kind of brand worldwide not only for Indonesia and not only for footwear brands. WOM can be enhanced by the implementation of IS, MBE and OE. BSC will also be promoted by this research which has significantly contributed in enhancing the understanding of BSC and why it is important for WOM. Moreover, brands can implement IS, MBE and OE for enhancement of their positive WOM. The brands can also use stronger BSC to ensure that WOM by their consumers is positive for their potential customers.



3

Limitations and Future Research Indications

The focus of **this** research was **only the** footwear brands of the Indonesia however any sector or brand could use WOM to attract potential customers. The study could have been conducted twice in order to compare the results before and after the education of implementation of IS, MBE and OE. Moreover, the study could have focused on footwear brands outside the Indonesia as well for the generalisation and validity of the results globally.



REFERENCES

- Ahmad, A., & Thyagaraj, K. (2015). Impact of brand personality on brand equity: The role of brand trust, brand attachment, and brand commitment. *Indian Journal of Marketing*, 45(5), 14-26.
- An, J., Do, D. K. X., Ngo, L. V., & Quan, T. H. M. (2019). Turning brand credibility into positive word-of-mouth: integrating the signaling and social identity perspectives. *Journal of Brand Management*, 26(2), 157-175.
- Anam, H., & Faiz, R. (2016). An empirical examination of brand loyalty via customer delight in Pakistan. *Journal of Management and Research*, 3(1), 13-20.
- Babić Rosario, A., Sotgiu, F., De Valck, K., & Bijmolt, T. H. (2016). The effect of electronic word of mouth on sales: A meta-analytic review of platform, product, and metric factors. *Journal of Marketing Research*, 53(3), 297-318.
- Baker, A. M., Donthu, N., & Kumar, V. (2016). Investigating how word-of-mouth conversations about brands influence purchase and retransmission intentions. *Journal of Marketing Research*, 53(2), 225-239.
- Boateng, S. L. (2019). Online relationship marketing and customer loyalty: a signaling theory perspective. *International Journal of Bank Marketing*, 37(1), 226-240.
- Carraher, S. (2015). Signaling intelligence, signaling theory, Project A, and excellent management history research. *Journal of Management History*, 21(2).
- Chang, Y.-C., & Huang, L.-C. (2019). The Effect of Product Knowledge and Risk Perception on Consumers' Online Word-of-Mouth Search Behavior for the Bio-Agricultural Products—in the Case of Ganoderma Dietary Supplements. *International Journal of Environment, Agriculture and Biotechnology*, 4(2).
- Chu, S.-C., Lien, C.-H., & Cao, Y. (2019). Electronic word-of-mouth (eWOM) on WeChat: Examining the influence of sense of belonging, need for self-enhancement, and consumer engagement on Chinese travellers' eWOM. *International Journal of Advertising*, 38(1), 26-49.
- Chung, N., & Koo, C. (2015). The use of social media in travel information search. *Telematics and Informatics*, 32(2), 215-229.
- Cindy, C., & Balqiah, T. E. (2018). How Brand Excitement Can Enhance Emotional Responses of Local Fashion Brands in Indonesia?: Moderating of Ethnocentrism. *Asia-Pacific Management and Business Application*, 6(2), 56-67.
- Garcia-Prieto, P., & Scherer, K. R. (2016). Connecting social identity theory and cognitive appraisal theory of emotions *Social Identities* (pp. 189-208): Psychology Press.



- Hasegawa, T., & Matsuoka, Y. (2015). Climate change mitigation strategies in agriculture and land use in Indonesia. *Mitigation and adaptation strategies for global change*, 20(3), 409-424.
- Herrero, Á., San Martín, H., & Hernández, J. M. (2015). How online search behavior is influenced by user-generated content on review websites and hotel interactive websites. *International Journal of Contemporary Hospitality Management*, 27(7), 1573-1597.
- Hogg, M. A. (2016). Social identity theory *Understanding peace and conflict through social identity theory* (pp. 3-17): Springer.
- Hudson, S., Roth, M. S., Madden, T. J., & Hudson, R. (2015). The effects of social media on emotions, brand relationship quality, and word of mouth: An empirical study of music festival attendees. *Tourism Management*, 47, 68-76.
- Islam, J. U., & Rahman, Z. (2016). Linking customer engagement to trust and word-of-mouth on Facebook brand communities: An empirical study. *Journal of Internet Commerce*, 15(1), 40-58.
- Khan, I., & Rahman, Z. (2015). Brand experience formation mechanism and its possible outcomes: a theoretical framework. *The Marketing Review*, 15(2), 239-259.
- Kirono, D. G., Butler, J. R., McGregor, J. L., Ripaldi, A., Katzfey, J., & Nguyen, K. (2016). Historical and future seasonal rainfall variability in Nusa Tenggara Barat Province, Indonesia: Implications for the agriculture and water sectors. *Climate Risk Management*, 12, 45-58.
- Kis-Katos, K., & Sparrow, R. (2015). Poverty, labor markets and trade liberalization in Indonesia. *Journal of Development Economics*, 117, 94-106.
- Klein, J. F., Falk, T., Esch, F.-R., & Gloukhovtsev, A. (2016). Linking pop-up brand stores to brand experience and word of mouth: The case of luxury retail. *Journal of Business Research*, 69(12), 5761-5767.
- Kucukemiroglu, S., & Kara, A. (2015). Online word-of-mouth communication on social networking sites: An empirical study of Facebook users. *International journal of commerce and management*, 25(1), 2-20.
- Lee, W.-I., Cheng, S.-Y., & Shih, Y.-T. (2017). Effects among product attributes, involvement, word-of-mouth, and purchase intention in online shopping. *Asia Pacific Management Review*, 22(4), 223-229.
- Li, H., Fang, Y., Wang, Y., Lim, K. H., & Liang, L. (2015). Are all signals equal? Investigating the differential effects of online signals on the sales performance of e-marketplace sellers. *Information Technology & People*, 28(3), 699-723.



- Li, J., Tang, J., Jiang, L., Yen, D. C., & Liu, X. (2019). Economic success of physicians in the online consultation market: a signaling theory perspective. *International Journal of Electronic Commerce*, 23(2), 244-271.
- Mathwick, C., & Mosteller, J. (2017). Online reviewer engagement: A typology based on reviewer motivations. *Journal of Service Research*, 20(2), 204-218.
- Mattsson, J., & Söderlund, M. (2017). *Thinking about the service encounter enhances encounter-related word-of-mouth*. Paper presented at the Quality in Services.
- Meyer, I., Durrheim, K., & Foster, D. (2016). Social Identity Theory as a theory of change: The case of South Africa *Understanding peace and conflict through Social Identity Theory* (pp. 167-184): Springer.
- Mukhlis, I., Utomo, S. H., & Soesetio, Y. (2015). The role of taxation education on taxation knowledge and its effect on tax fairness as well as tax compliance on handicraft SMEs sectors in Indonesia. *International Journal of Financial Research*, 6(4), 161-169.
- Park, J. Y., O'Hare, N., Schifanella, R., Jaimes, A., & Chung, C.-W. (2015). *A large-scale study of user image search behavior on the web*. Paper presented at the Proceedings of the 33rd Annual ACM Conference on Human Factors in Computing Systems.
- Rachbini, W., Haryani Hatta, I., & Evi, T. (2019). Determinants of Trust and Customer Loyalty on C2C E-marketplace in Indonesia. *International Journal of Civil Engineering and Technology*, 10(3).
- Rialti, R., Zollo, L., Caliendo, A., & Ciappei, C. (2017). *EXPLORING THE LINK BETWEEN CONSUMERS' ENGAGEMENT AND E-WORD OF MOUTH IN SOCIAL MEDIA BRAND COMMUNITIES: A PATH ANALYSIS*. Paper presented at the 2017 Global Fashion Management Conference at Vienna.
- Riivits-Arkonsuo, I., & Leppiman, A. (2015). Antecedents of online word-of-mouth and memorable experience concept. *International Journal of Business and Social Research*, 5(9), 01-14.
- Setiawan, D. V. (2018). *The impact of brand image, service quality, and sales promotion on customer repurchase intention through customer satisfaction at Tokopedia in Surabaya*. Widya Mandala Catholic University Surabaya.
- Sidharta, I., & Affandi, A. (2016). The empirical study on intellectual capital approach toward financial performance on rural banking sectors in Indonesia. *International Journal of Economics and Financial Issues*, 6(3), 1247-1253.
- Su, W., Peng, M. W., Tan, W., & Cheung, Y.-L. (2016). The signaling effect of corporate social responsibility in emerging economies. *Journal of business Ethics*, 134(3), 479-491.



- Sutia, S., Adha, S., & Fahlevi, M. (2019). *Why do Customers Intend to Repurchase Transportation Online in Indonesia?* Paper presented at the E3S Web of Conferences.
- Syahriwar, J., & Ichlas, A. M. (2018). The Impact of Electronic Word of Mouth (E-WoM) on Brand Equity of Imported Shoes: Does a Good Online Brand Equity Result in High Customers' Involvements in Purchasing Decisions? *The Asian Journal of Technology Management, 11*(1), 57-69.
- Wang, Y., & Yu, C. (2017). Social interaction-based consumer decision-making model in social commerce: The role of word of mouth and observational learning. *International Journal of Information Management, 37*(3), 179-189.
- Wu, J., Fan, S., & Zhao, J. L. (2018). Community engagement and online word of mouth: An empirical investigation. *Information & Management, 55*(2), 258-270.
- You, Y., Vadakkepatt, G. G., & Joshi, A. M. (2015). A meta-analysis of electronic word-of-mouth elasticity. *Journal of Marketing, 79*(2), 19-39.
- Yu, M., Liu, F., Lee, J., & Soutar, G. (2018). The influence of negative publicity on brand equity: attribution, image, attitude and purchase intention. *Journal of Product & Brand Management, 27*(4), 440-451.
- Zarrad, H., & Debabi, M. (2015). Analyzing the effect of electronic word of mouth on tourists' attitude toward Destination and Travel Intention. *International research journal of social sciences, 4*(4), 53-60.
- Zhang, M., Hu, M., Guo, L., & Liu, W. (2017). Understanding relationships among customer experience, engagement, and word-of-mouth intention on online brand communities: The perspective of service ecosystem. *Internet Research, 27*(4), 839-857.
- Zhao, Y., Liu, Y., Lai, I., Zhang, H., & Zhang, Y. (2016). The impacts of attitudes and engagement on Electronic Word of Mouth (eWOM) of mobile sensor computing applications. *Sensors, 16*(3), 391.

A Model to Get Positive Word of Mouth for Indonesian Footwear Brands: Role of Information Search, Online Engagement, Memorial Brand Experience and Brand Social Connection

ORIGINALITY REPORT

16%

SIMILARITY INDEX

9%

INTERNET SOURCES

9%

PUBLICATIONS

10%

STUDENT PAPERS

PRIMARY SOURCES

1

Submitted to Universitas 17 Agustus 1945
Surabaya

Student Paper

5%

2

Submitted to Universitat Mannheim

Student Paper

3%

3

Maneerat Mitprasat, Pissanu Horakul, Rofiqu
Umam. "Analyzing the impact of organic
certification on product and sustainable
attributes on the importance of organic food
certification in Thailand: Mediating role of
perceived benefits of organic food", World Food
Policy, 2020

Publication

2%

4

Parinya Siriattakul, Khajornsak Thaiprayoon,
Ahmad Harakan. "Managing subjective well-
being of organic food consumers through
sustainability orientation, environmental
consciousness, and skepticism in Thailand:
Mediating role of organic food consumption",

1%

World Food Policy, 2019

Publication

5	www.statista.com Internet Source	1%
6	eprints.ulm.ac.id Internet Source	1%
7	Kittisak Jermsittiparsert, Muhammad Haseeb, Mohammed Dawabsheh. "Enhancing organic food identity through green marketing in Thailand: Mediating role of environmental, health, and social consciousness", World Food Policy, 2020 Publication	1%
8	anzmac.wildapricot.org Internet Source	1%
9	usir.salford.ac.uk Internet Source	1%
10	www.tandfonline.com Internet Source	1%

Exclude quotes On

Exclude matches < 1%

Exclude bibliography On